



Scorpio Automation™

www.scorpioautomation.in

Automatic Sliding Gates



Application:

Industries, factory, goods yard, commercial premises, apartment block access shopping malls, hospitals, stadiums, business centers, and so on.

Automatic Sliding Gates

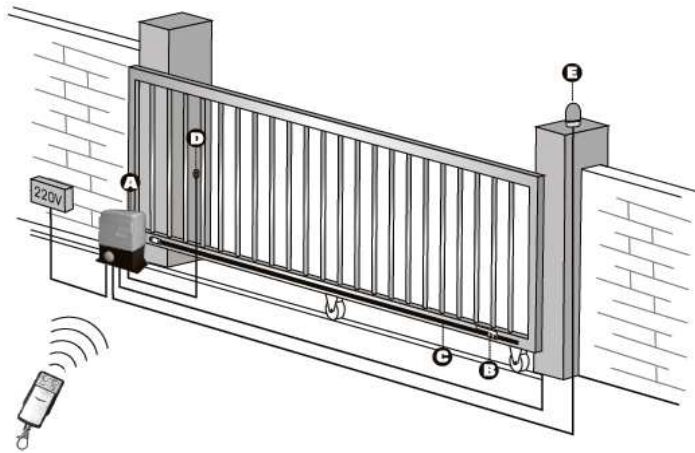

Technical data:

Motor power: AC220V 370W
Frequency: 50(60)Hz
W.T(kg) : 16kg
Motor rotational speed: 1400 r/min
Output rotational speed: 46 r/min
Gate max weight: 500 – 4000Kg
Reduce ratio: 30 : 1
Gear Box material: Aluminum alloy

Advanced Features:

- It is an integration machine of mechanism and electronics. No need to install another controller.
- Opening, closing and stop are controlled by radio controller or line controller.
- Soft start ensures the machine works smoothly.
- If meet obstacle when closing, it will automatically open and close in 10 seconds.
- Alarm light will inform you that the door is moving.
- Photocell connecting interface.
- Automatically return for resistance.

Safety Features:

- Die-casting aluminum alloy
- Max. Weight of Gate 4000kg
- Soft Start YES
- Stop on obstacle (sensitivity adjustable) – YES
- Remote control 418MHZ (50m, approx)
- Wire control - YES
- Auto closing - YES
- Vehicle loop detector socket - YES
- Photocell socket – YES

Sliding Gate Motor Models:

Model	Gate Operator	Specification										
SMSGM600H		<table border="1"> <tr> <td>Voltage</td> <td>AC220V</td> </tr> <tr> <td>Output Power</td> <td>350W</td> </tr> <tr> <td>Motor rotational speed</td> <td>1620rpm</td> </tr> <tr> <td>Working Temperature</td> <td>-40°C~+55°C</td> </tr> <tr> <td>Gate max weight:</td> <td>600kg</td> </tr> </table>	Voltage	AC220V	Output Power	350W	Motor rotational speed	1620rpm	Working Temperature	-40°C~+55°C	Gate max weight:	600kg
Voltage	AC220V											
Output Power	350W											
Motor rotational speed	1620rpm											
Working Temperature	-40°C~+55°C											
Gate max weight:	600kg											
SMSGM400H2		<table border="1"> <tr> <td>Voltage</td> <td>24DC/60W</td> </tr> <tr> <td>Output Power</td> <td>60W</td> </tr> <tr> <td>Motor rotational speed</td> <td>2200 rpm</td> </tr> <tr> <td>Working Temperature</td> <td>-40°C~+55°C</td> </tr> <tr> <td>Gate max weight:</td> <td>300kg</td> </tr> </table>	Voltage	24DC/60W	Output Power	60W	Motor rotational speed	2200 rpm	Working Temperature	-40°C~+55°C	Gate max weight:	300kg
Voltage	24DC/60W											
Output Power	60W											
Motor rotational speed	2200 rpm											
Working Temperature	-40°C~+55°C											
Gate max weight:	300kg											
SMSGM400H		<table border="1"> <tr> <td>Voltage</td> <td>AC220V</td> </tr> <tr> <td>Output Power</td> <td>370W</td> </tr> <tr> <td>Motor rotational speed</td> <td>1400 rpm</td> </tr> <tr> <td>Working Temperature</td> <td>-40°C~+55°C</td> </tr> <tr> <td>Gate max weight:</td> <td>300kg</td> </tr> </table>	Voltage	AC220V	Output Power	370W	Motor rotational speed	1400 rpm	Working Temperature	-40°C~+55°C	Gate max weight:	300kg
Voltage	AC220V											
Output Power	370W											
Motor rotational speed	1400 rpm											
Working Temperature	-40°C~+55°C											
Gate max weight:	300kg											
SMSGM600HCC		<table border="1"> <tr> <td>Voltage</td> <td>AC220V</td> </tr> <tr> <td>Output Power</td> <td>250W</td> </tr> <tr> <td>Motor rotational speed</td> <td>1400 rpm</td> </tr> <tr> <td>Working Temperature</td> <td>-40°C~+55°C</td> </tr> <tr> <td>Gate max weight:</td> <td>500kg</td> </tr> </table>	Voltage	AC220V	Output Power	250W	Motor rotational speed	1400 rpm	Working Temperature	-40°C~+55°C	Gate max weight:	500kg
Voltage	AC220V											
Output Power	250W											
Motor rotational speed	1400 rpm											
Working Temperature	-40°C~+55°C											
Gate max weight:	500kg											

SMSGM8H-ML

Voltage	AC220V
Output Power	250W
Motor rotational speed	1400 rpm
Working Temperature	-40°C~+55°C
Gate max weight:	600kg

SMSGM1kH-MLR

Voltage	AC220V
Output Power	450W
Motor rotational speed	1400 rpm
Working Temperature	-40°C~+55°C
Gate max weight:	1000kg

SMSGM1kH-ML

Voltage	AC220V
Output Power	370W
Motor rotational speed	1400 rpm
Working Temperature	-40°C~+55°C
Gate max weight:	1000kg

SMSGM15kH-ML

Voltage	AC220V
Output Power	450W
Motor rotational speed	1400 rpm
Working Temperature	-40°C~+55°C
Gate max weight:	1500kg

ACCESSORIES

Main Control Board



Photo Beam Safety Sensor



Loop Deduct or



Remote Transmitter



Gear Rack



Infrared Photocell



Pushbutton Switch



Flashing Lamps

