

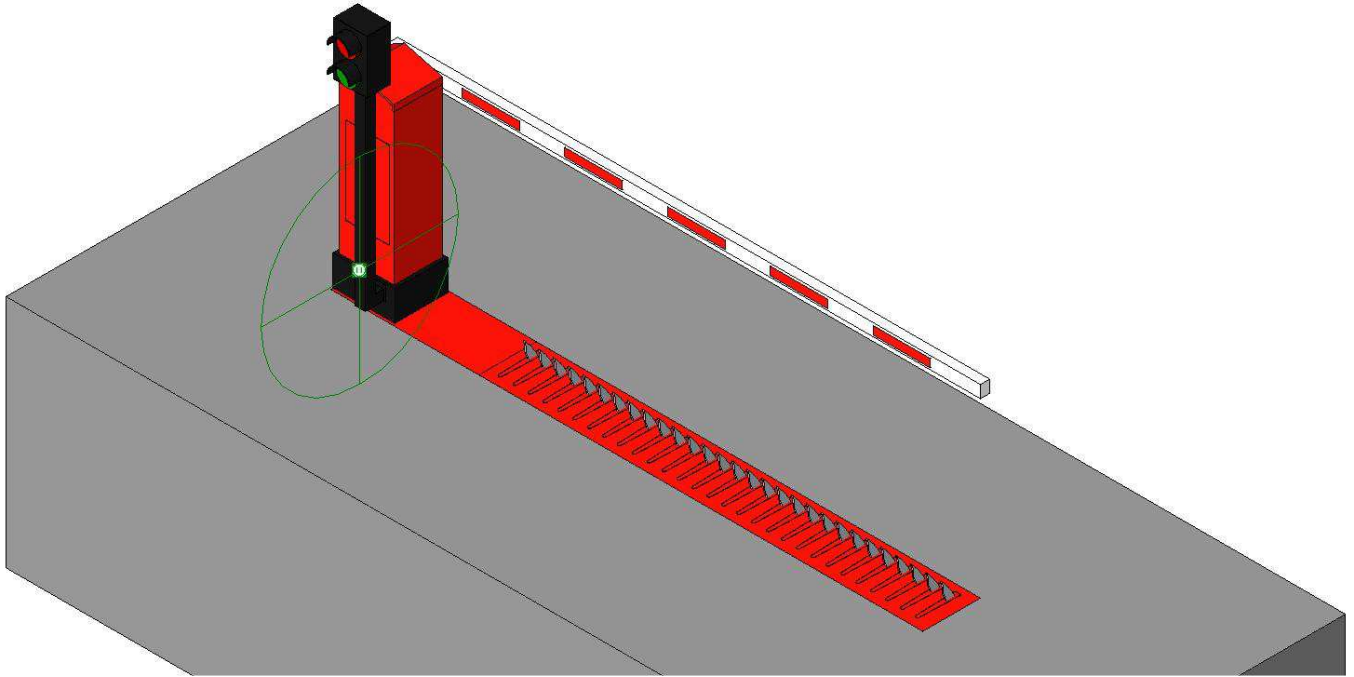

**Scorpio Automation**<sup>TM</sup>

[www.scorpioautomation.in](http://www.scorpioautomation.in)

## Automatic Spike Barrier



### Applications:

- Bus Gates
- Congestion Zones
- Residential Areas
- Car Parks
- Private Security
- Pedestrian Zones
- Government Buildings
- Shopping Centers
- Commercial/Industrial Sites
- Nuclear Installations

# Spike Barrier

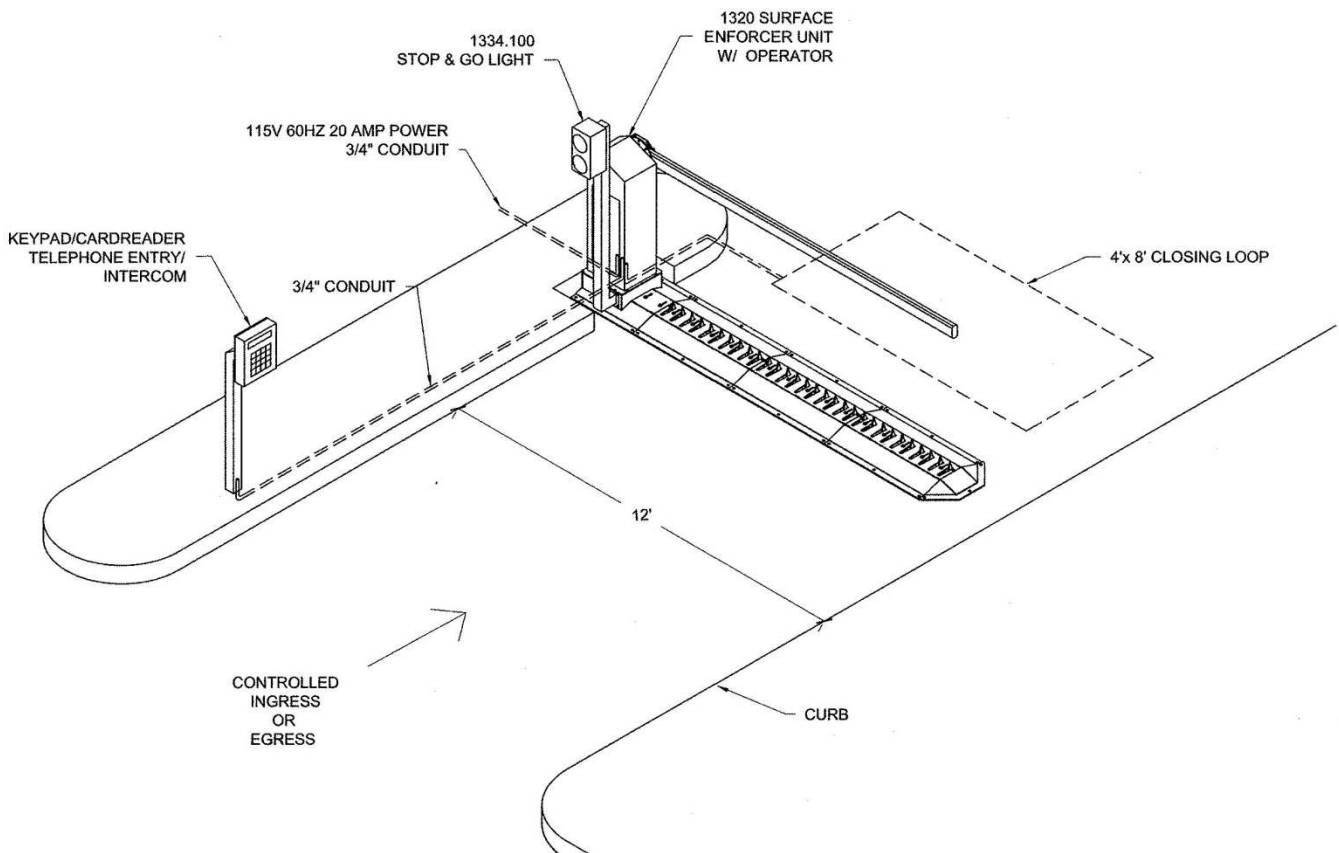

## Specifications:

Items	Spike Barrier
Application range	Intersection safe protection in main area
Material	Q235 steel/A3 steel
Surface treatment	Paint with reflective stripe
IP	IP67
Standard color	Black and yellow
Length	≤10000mm
Width	580mm
Height from ground	70~110mm
Min weight capacity	40T
Blade height	150mm
Blade thickness	10mm
Operation mode	Electromechanical
Working environment	-40°C~+70°C
Control mode	Short range wireless remote control/drive-by-wire
Control distance	≤100M
Up/Down speed	2s
Voltage	220V