

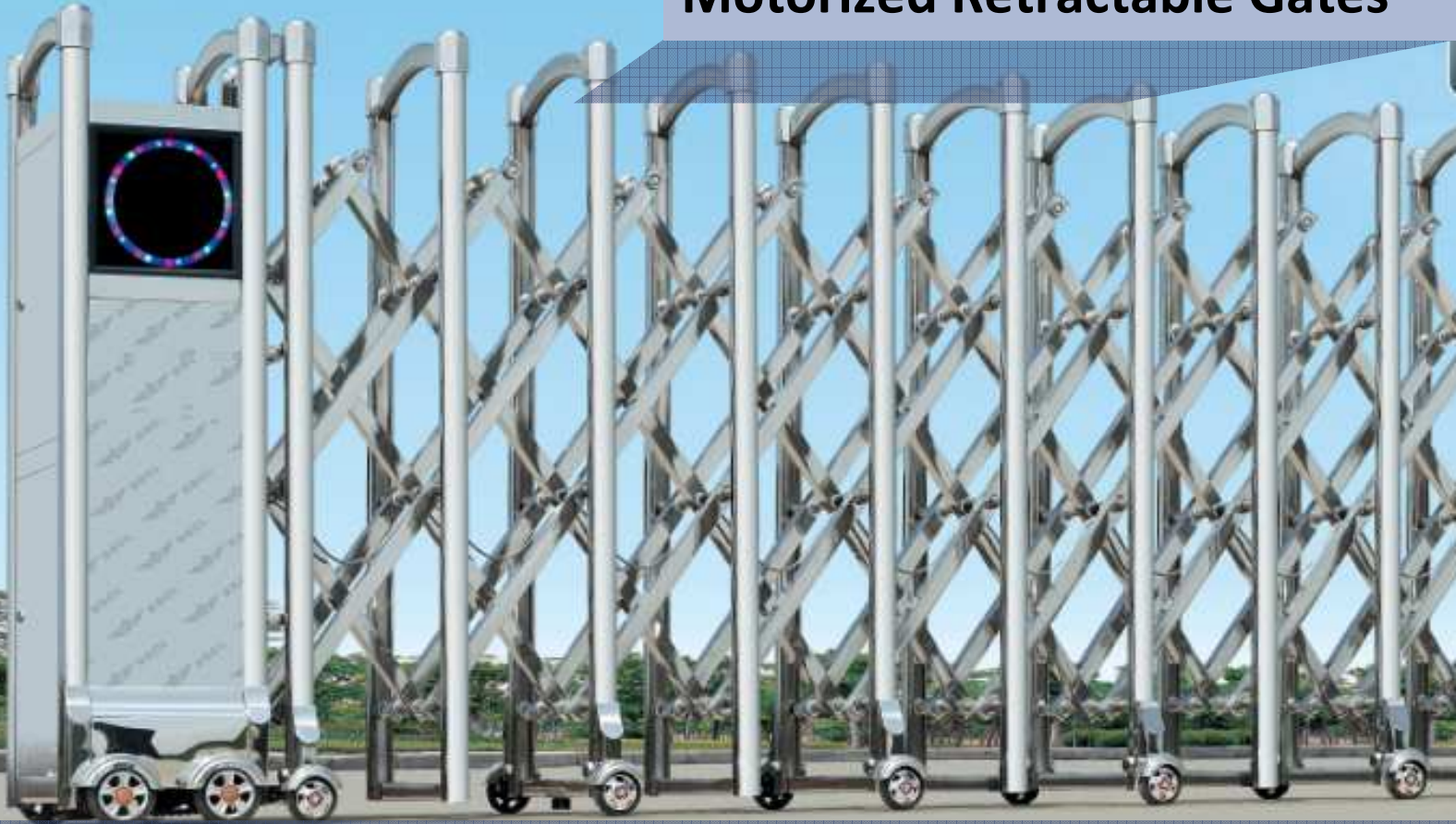

**Scorpio Automation™**

[www.scorpioautomation.in](http://www.scorpioautomation.in)

## Motorized Retractable Gates



### Application:

Industries, Factory, Goods yard, Commercial premises, Apartments, Access shopping malls, Hospitals, Stadiums, Business centers, and so on.

# Automatic Retractable gates



## Specification:

- Material: 304 Stainless Steel
- Major material: 50\*50\*0.7mm
- Auxiliary Material: 46\*36\*0.6mm
- Auxiliary Material: 38\*25\*0.6mm
- Wheel: casting aluminum 3.3 cross net tubes
- Heavy duty Motor+ LED+ Remote (20mtr /min)

<b>AC Input Voltage</b>	<b>220V/50HZ</b>
<b>AC Input Power</b>	220V/5HZ / 350Watts~1000 Watts
<b>Speed of Open</b>	Suitable for Max 20mt/Minute
<b>Motor</b>	Intelligent Gear Motor
<b>Gate Size</b>	Height 1.2- 2 Mt / Width 3-30Mt
<b>Track Type</b>	Single/Double/Trackless
<b>Manual Operation</b>	By Clutch Key on Power Fail
<b>Standard Accessories</b>	Electric Switch/Remote Controller/Clutch Keys for Manual Operation with User Manual
<b>Gate Material</b>	Stainless Steel / Aluminum
<b>Controller</b>	Microprocessor Based controller

# Stainless Steel Materials

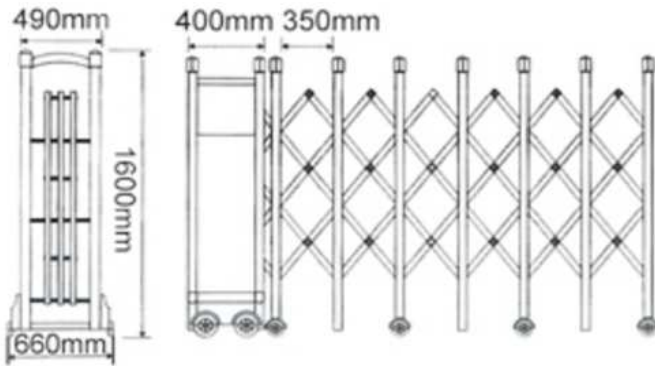

# Aluminum Retractable Gate

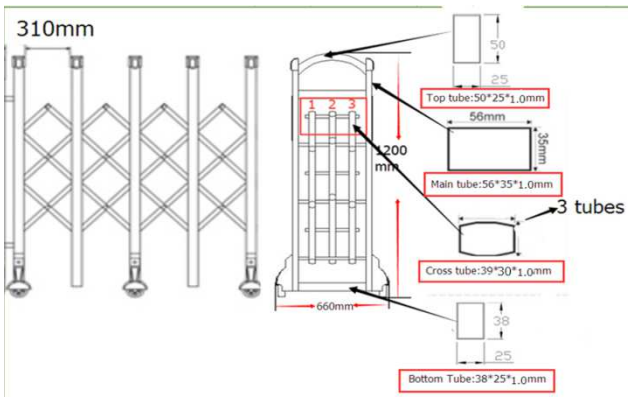

Material	201 SS / 304SS / AL
Height (MM)	1200 - 1800
Width(MM)	660
Weight of gate	Max 1000 Kg
Wheel Base (center -center)	600-610mm
Working Temp	-35+75°C
Moving Speed (mtrs/min)	17-19m/min
Remote Control with range	≤50m
Main Parts Material	50*50*0.7mm
Vice Parts Material	46*36*0.6mm
Power Consumption	420W
Motor Tracking Options	Single track / Double track /Trackless
Colors	Steel color
LED Display(Optional Accessories)	1 set
Alarm Light(Optional Accessories)	1 set
Anti-Climb alarm system	1set
Motor Overheating Protection	yes
Speed Clutch	1pc
Infrared Anti-Collision Device	1pc
Anti-Climb Alarm (Optional)	1 set

## ACCESSORIES

Motor

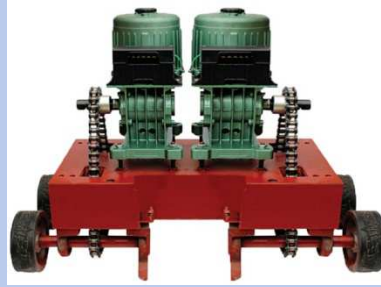

Control Panel



Rolling Display Screen



Magic Eye Alarm



Anti crash Device



Robot Navigation



Alarm Light



Wireless Remote Control



Wheel

